



smavit

Catalogo Prodotti
Scaldabagno elettrico

Scaldabagno Smaltato
Smavit
Tecnologia di Smaltatura
dal 1961



Smavit

MEDITERRANEO PRO

Capacità

Verticale : 30-50- 80-100-150 litri
 Orizzontale : 50- 80-100-150 litri



Verticale



Orizzontale



Caratteristiche principali

- Smaltatura eco-friendly Smavit Pro+
- Caldaia protetta da Smalto Vetrificato
- Anodo di Magnesio di grandi dimensioni
- Poliuretano senza cloro fluoro carburi
- Termometro resistente agli urti in ABS
- Indicatore acceso/spento
- Resistenza in Acciaio Inox ultrasensibile
- Termostato di Precisione
- Selettore di Temperatura
- Sistema di chiusura con flangia a 5 bulloni



Flangia a 5 bulloni



Selettore di Temperatura



Anodo di magnesio



Caldaia vetroporcellanata



Tripla sicurezza



Regolazione della temperatura



Isolamento senza CFC



Indicatore di energia

Dimensioni

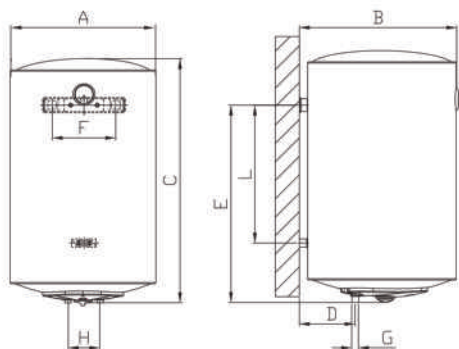

Verticale

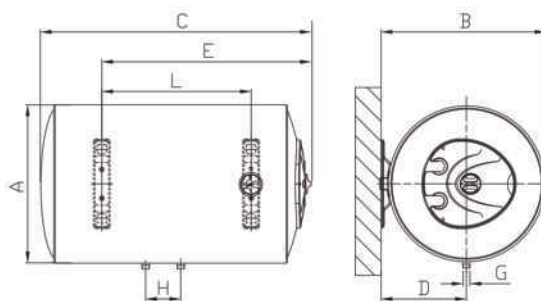

Orizzontale

Data tecnici

Modello		SVV30	SVV50	SVV80	SVV100	SVV150	SVH50	SVH80	SVH100	SVH150
Capacità	litri	30	50	80	100	150	50	80	100	150
Dimensioni (mm)	A	368	450	450	450	450	450	450	450	450
	B	390	472	472	472	472	472	472	472	472
	C	522	578	809	973	1279	578	809	973	1279
	D	123	158	158	158	158	263	263	263	263
	E	342	401	632	796	1102	401	632	796	1102
	F	270	270	270	270	270	196	196	196	196
	G	1/2"	1/2"	1/2"	1/2"	1/2"	1/2"	1/2"	1/2"	1/2"
	H	100	100	100	100	100	100	100	100	100
L	140	199	430	549	855	154	385	549	855	
Temperatura Esercizio	MPa	0.8	0.8	0.8	0.8	0.8	0.8	0.8	0.8	0.8
Watt	W	1500	1500	1500	1500	1500	1500	1500	1500	1500
Spessore Isolamento	mm	19	25	25	25	25	25	25	25	25
Tempo Riscaldamento	min	1h.20'	2h.02'	3h.16'	4h.09'	3h.24'	1h.37'	3h.16'	4h.09'	4h.53'
Peso Netto	kg	13.7	16.79	22.54	26.97	34.6	18.0	21.8	27.51	33.5
Peso Lordo	kg	14.5	18.79	25.54	29.97	38.6	20.1	24.88	30.51	37.0
Quantità in Container	40HQ	745	470	340	285	220	546	340	285	214
	20GP	312	197	142	120	92	232	143	120	94

MEDITERRANEO

Capacità

Verticale : 30-50- 80-100-150 litri
 Orizzontale : 50- 80-100-150 litri



Verticale



Orizzontale



Caratteristiche principali

- Smaltatura eco-friendly Smavit standard
- Caldaia protetta da Smalto Vetrificato
- Anodo di Magnesio
- Poliuretano senza cloro fluoro carburi
- Termometro resistente agli urti in ABS
- Indicatore acceso/spento
- Resistenza in Acciaio Inox ultrasensibile
- Termostato di Precisione
- Selettore di Temperatura
- Sistema di chiusura con flangia a 5 bulloni



Flangia a 5 bulloni



Selettore di Temperatura



Anodo di magnesio



Caldaia vetroporcellanata



Tripla sicurezza



Regolazione della temperatura



Isolamento senza CFC



Indicatore di energia

Dimensioni

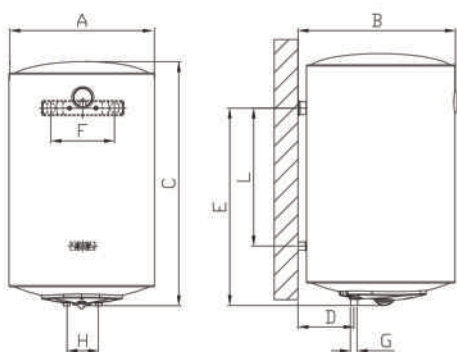

Verticale

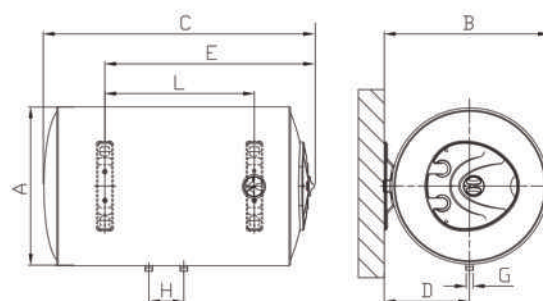

Orizzontale

Data tecnici

Modello		SVV30	SVV50	SVV80	SVV100	SVV150	SVH50	SVH80	SVH100	SVH150
Capacità	litri	30	50	80	100	150	50	80	100	150
Dimensioni (mm)	A	368	450	450	450	450	450	450	450	450
	B	390	472	472	472	472	472	472	472	472
	C	522	578	809	973	1279	578	809	973	1279
	D	123	158	158	158	158	263	263	263	263
	E	342	401	632	796	1102	401	632	796	1102
	F	270	270	270	270	270	196	196	196	196
	G	1/2"	1/2"	1/2"	1/2"	1/2"	1/2"	1/2"	1/2"	1/2"
	H	100	100	100	100	100	100	100	100	100
L	140	199	430	549	855	154	385	549	855	
Temperatura Esercizio	MPa	0.8	0.8	0.8	0.8	0.8	0.8	0.8	0.8	0.8
Watt	W	1500	1500	1500	1500	1500	1500	1500	1500	1500
Spessore Isolamento	mm	19	25	25	25	25	25	25	25	25
Tempo Riscaldamento	min	1h.20'	2h.02'	3h.16'	4h.09'	3h.24'	1h.37'	3h.16'	4h.09'	4h.53'
Peso Netto	kg	13.7	16.79	22.54	26.97	34.6	18.0	21.8	27.51	33.5
Peso Lordo	kg	14.5	18.79	25.54	29.97	38.6	20.1	24.88	30.51	37.0
Quantità in Container	40HQ	745	470	340	285	220	546	340	285	214
	20GP	312	197	142	120	92	232	143	120	94

JONIO PRO

Capacità

Sopra Lavello : 10-15-30 litri

Sotto Lavello : 10-15 litri



Caratteristiche principali

- Smaltatura eco-friendly Smavit Standard
- Caldaia protetta da Smalto Vetrificato
- Anodo di Magnesio di grandi dimensioni
- Poliuretano senza cloro fluoro carburi
- Resistenza in Acciaio Inox ultrasensibile
- Termostato di Precisione
- Selettore di Temperatura
- Sistema di chiusura con flangia a 5 bulloni
- Contenitore Esterno in Plastica



Isolamento senza CFC



Tripla sicurezza



Anodo di magnesio



Caldaia vetroporcellanata



Involucro esterno a prova di shock



Parti Reciclate



Regolazione della temperatura

Dimensioni

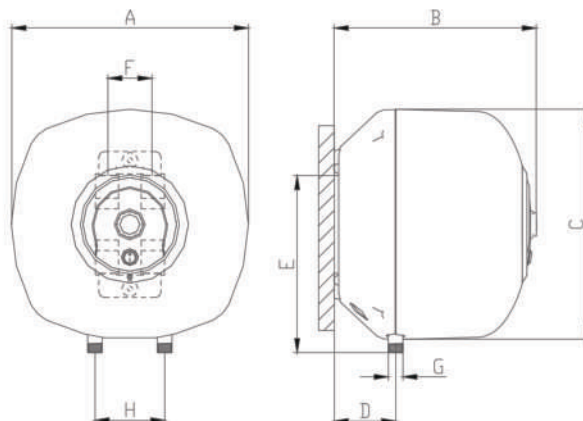

Data tecnici

Modello		SVK10	SVK10 U	SVK15	SVK15 U	SVK30
Capacità	litri	10	10	15	15	30
Dimensioni (mm)	A	340	340	360	360	440
	B	391	391	329	329	389
	C	347	347	375	375	455
	D	90	90	97	97	113
	E	252	114	265	125	318
	F	66	66	66	66	66
	G	1/2"	1/2"	1/2"	1/2"	1/2"
	H	100	100	100	100	100
	L	-	-	-	-	-
Temperatura Esercizio	MPa	0.8	0.8	0.8	0.8	0.8
Watt	W	1500	1500	1500	1500	1500
Spessore Isolamento	mm	20	20	20	20	20
Tempo Riscaldamento	min	26'	26'	40'	40'	1h.20'
Peso Netto	kg	6.5	6.5	7.8	7.8	11.5
Peso Lordo	kg	7.7	7.7	9.5	9.5	13.5
Quantità in Container	40HQ	1529	1529	1080	1080	740
	20GP	672	672	450	450	300

JONIO

Capacità

Sopra Lavello : 10-15-30 litri

Sotto Lavello : 10-15 litri



Caratteristiche principali

- Smaltatura eco-friendly Smavit Standard
- Caldaia protetta da Smalto Vetrificato
- Anodo di Magnesio di grandi dimensioni
- Poliuretano senza cloro fluoro carburi
- Resistenza in Acciaio Inox ultrasensibile
- Termostato di Precisione
- Selettore di Temperatura
- Sistema di chiusura con flangia a 5 bulloni
- Contenitore Esterno in Plastica



Isolamento
senza CFC



Tripla
sicurezza



Anodo di
magnesio



Caldaia
vetroporcellanata



Involucro
esterno a
prova di
shock



Parti
Reciclate



Regolazione
della
temperatura

Dimensioni

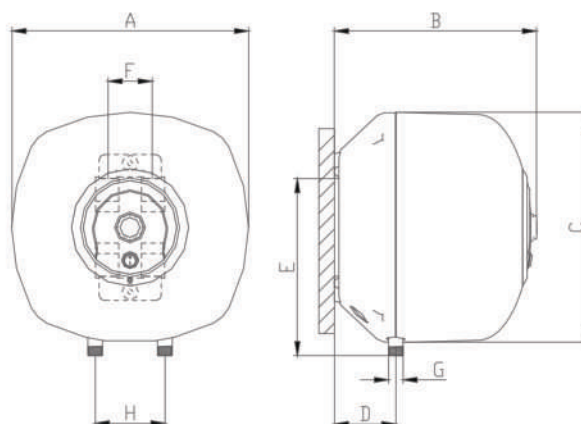

Data tecnici

Modello		SVK10	SVK10 U	SVK15	SVK15 U	SVK30
Capacità	litri	10	10	15	15	30
Dimensioni (mm)	A	340	340	360	360	440
	B	391	391	329	329	389
	C	347	347	375	375	455
	D	90	90	97	97	113
	E	252	114	265	125	318
	F	66	66	66	66	66
	G	1/2"	1/2"	1/2"	1/2"	1/2"
	H	100	100	100	100	100
	L	-	-	-	-	-
Temperatura Esercizio	MPa	0.8	0.8	0.8	0.8	0.8
Watt	W	1500	1500	1500	1500	1500
Spessore Isolamento	mm	20	20	20	20	20
Tempo Riscaldamento	min	26'	26'	40'	40'	1h.20'
Peso Netto	kg	6.5	6.5	7.8	7.8	11.5
Peso Lordo	kg	7.7	7.7	9.5	9.5	13.5
Quantità in Container	40HQ	1529	1529	1080	1080	740
	20GP	672	672	450	450	300

LIGURE

Capacità

Sopra e sotto Livello : 5 litri



Caratteristiche principali

- Smaltatura eco-friendly Smavit Standard
- Caldaia protetta da Smalto Vetrificat
- Anodo di Magnesio di grandi dimensioni
- Poliuretano senza cloro fluoro carburi
- Resistenza in Acciaio Inox ultrasensibile
- Termostato di Precisione
- Selettore di Temperatura
- Sistema di chiusura con flangia a 5 bulloni
- Contenitore Esterno in Plastica



Flangia a 5 bulloni



Selettore di Temperatura



Anodo di magnesio



Caldaia vetroporcellanata



Tripla sicurezza



Regolazione della temperatura



Isolamento senza CFC



Indicatore di energia

Dimensioni

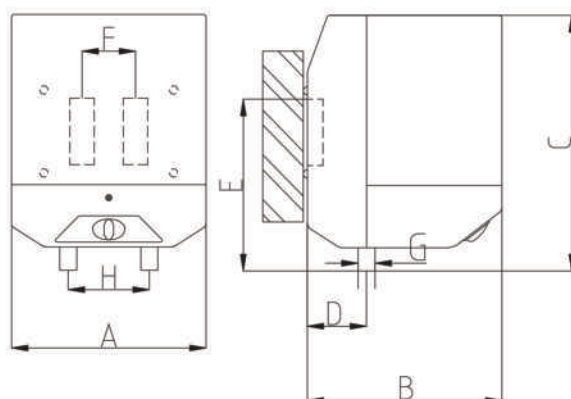

Data tecnici

Modello		SVK5	SVK5 U
Capacità	litri	5	5
Dimensioni (mm)	A	240	240
	B	240	240
	C	280	280
	D	76	76
	E	207	87
	F	66	66
	G	1/2"	1/2"
	H	100	100
	L	-	-
Temperatura Esercizio	MPa	0.8	0.8
Watt	W	2000	2000
Spessore Isolamento	mm	22	22
Tempo Riscaldamento	min	10'	10'
Peso Netto	kg	4.5	4.5
Peso Lordo	kg	6	6
Quantità in Container	40HQ	2376	2376
	20GP	1024	1024

SMAVIT s.p.a
Strada Sorianese, 27 01030
Vitorchiano (VT) Italy
Tel. (+39)0761 37601
Email info@smavit.com
www.smavit.it